

TYPE REF	NO.OF TUBES	DIMENSIONS			POST SECTION
		A	B	C	
3A	3	405	405	410nom	200x200
3B	3	375	375	250	200x200
2A	2	400	-	350	175x200
2B	2	500	-	500	200x200

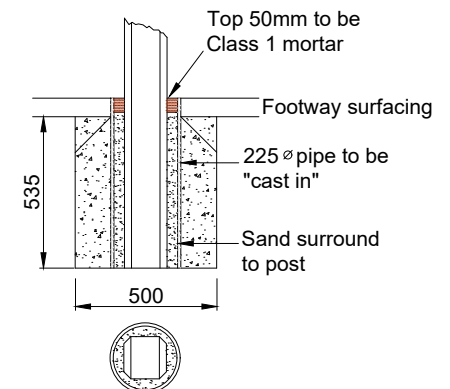

**ALTERNATIVE FOUNDATION
DETAIL IN PAVED AREA**

Notes:

- All dimensions are in millimetres unless otherwise stated.
- Steel tubes:
 - Railings to be galvanised steel tubing 48.3mm (size 8) 'Kee Klamp' standard fittings (or suitable alternative) with galvanised finish to be used where joints or end fixings required
 - End caps threaded as per socket (min. length B/2) drilled and tapped for stainless steel CSK locking screw.
 - Hot-dip zinc coating required to tubes, sockets, end caps.
 - Manufacturer's certificates required.
- Lengths of tube between sockets and end caps shall be described in Appendix 1/15 or 3/1.
- Post spacings shall be as detailed in Appendices and on the scheme Drawings.

5. Concrete Posts:

- Manufactured in accordance with BS1722:Part 3 for steel reinforced concrete, Section 2.3 for straining posts as applicable, (round top). Reinforcing stirrups to be provided above and below holes for tubes.
- Holes for tubes shall allow the tubes to be freely inserted. All holes shall be free from obstruction and accurately positioned. Holes for tubes shall be 57 nom. diameter.
- Should unequal post sections be used the major dimension shall be on the face containing holes for tubes.
- Records of results of cube tests for concrete relevant to the casting of posts shall be made available for inspection on site.

6. Erection: it is not necessary for the steel tube sockets to be able to pass through holes in posts.

- Where directed painting shall be white masonry paint on posts. Railings to be painted using "Finnegan's" or similar galvanised metal primer plus top coat of white "Hammerite" or similar using second coat where required within 3 hours. Paint to be applied in accordance with manufacturers recommendations.
- Where tube railing posts are to be set in paved or concreted areas the alternative foundation detail to be used as directed.



COUNTY HALL
Pegs Lane
Hertford, Herts
SG13 8DN
Phone: 01992 555555

Revisions

- A - AUG 23 UPDATED DETAIL
B -
C -

Drawing Title

**CONCRETE POSTS AND
STEEL TUBE FENCING**

Dwg No: HST/0300/005

Scale at A4 : N.T.S.

Drawn	Approved	Revised
RD	JE	
Checked	Date	Date
STM	JULY '11	