

**VARIATIONS FOR DIFFERENT GROUND CONDITIONS**

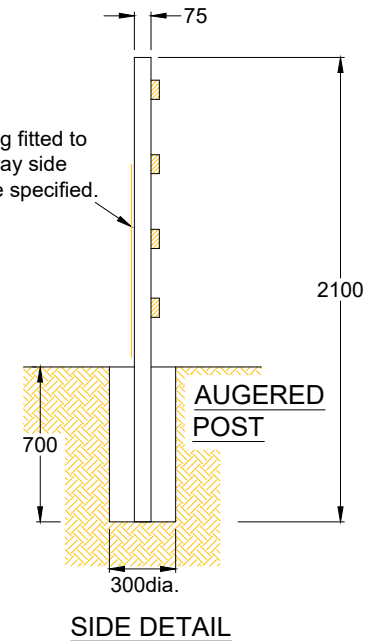

**Notes:**

- All dimensions are in millimetres unless otherwise stated.
- Materials and construction to be in accordance with current B.S. 1722: part 7.
- All timber and pressure treatment to be in accordance with the specification.
- When specified, painting to be in accordance with the specification.
- All posts set in concrete, to be set in 300 square hole. Posts may be driven in suitable ground with the permission of the Project Manager.
- Augered posts set in 300 dia. hole should be backfilled with suitable excavated material being well compacted as filling proceeds. If excavated material is unacceptable for backfilling post holes shall, at the direction of the Project Manager, be backfilled to at least half their depth with Concrete Class GEN2.
- Where specified Stock proof netting to comply with current B.S. 1722 part 2.
- Top of posts to be shaped to disperse water.
- Netting secured to posts by each horizontal wire with 1 No. 40x8 S.W.G. galvanised staple

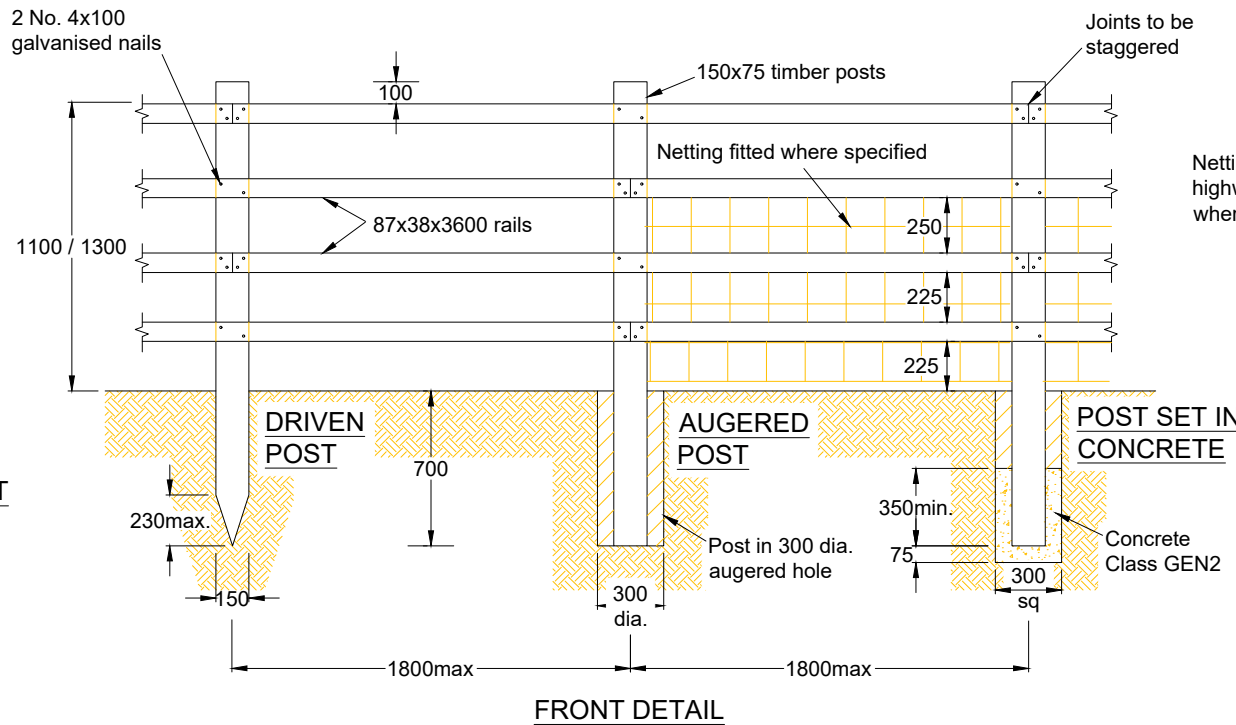
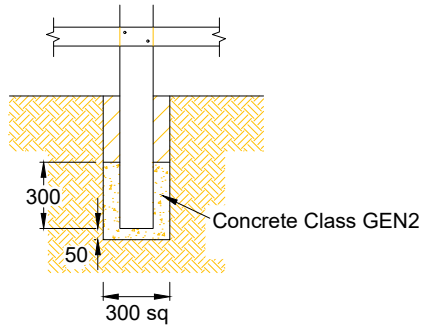
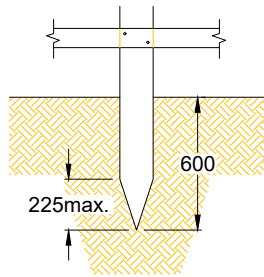

COUNTY HALL  
Pegs Lane  
Hertford, Herts  
SG13 8DN  
Phone: 01992 555555

**Revisions**

- A - AUG 23 UPDATED DETAIL  
B -  
C -

**Drawing Title**

NAILED WOODEN POST  
AND FOUR RAIL FENCE  
TYPE MPR & SPR

Dwg No: HST/0300/010

Scale at A4 : N.T.S.

Drawn	Approved	Revised
RD	JE	
Checked	Date	Date
STM	JULY '11	