

ALL DIMENSIONS ARE IN MILLIMETRES
UNLESS OTHERWISE STATED

TYPICAL DETAILS OF BRICK MANHOLES - TYPE B
(Pipe diameter 100 - 450, depth to top of base slab 1.3m - 3.0m)

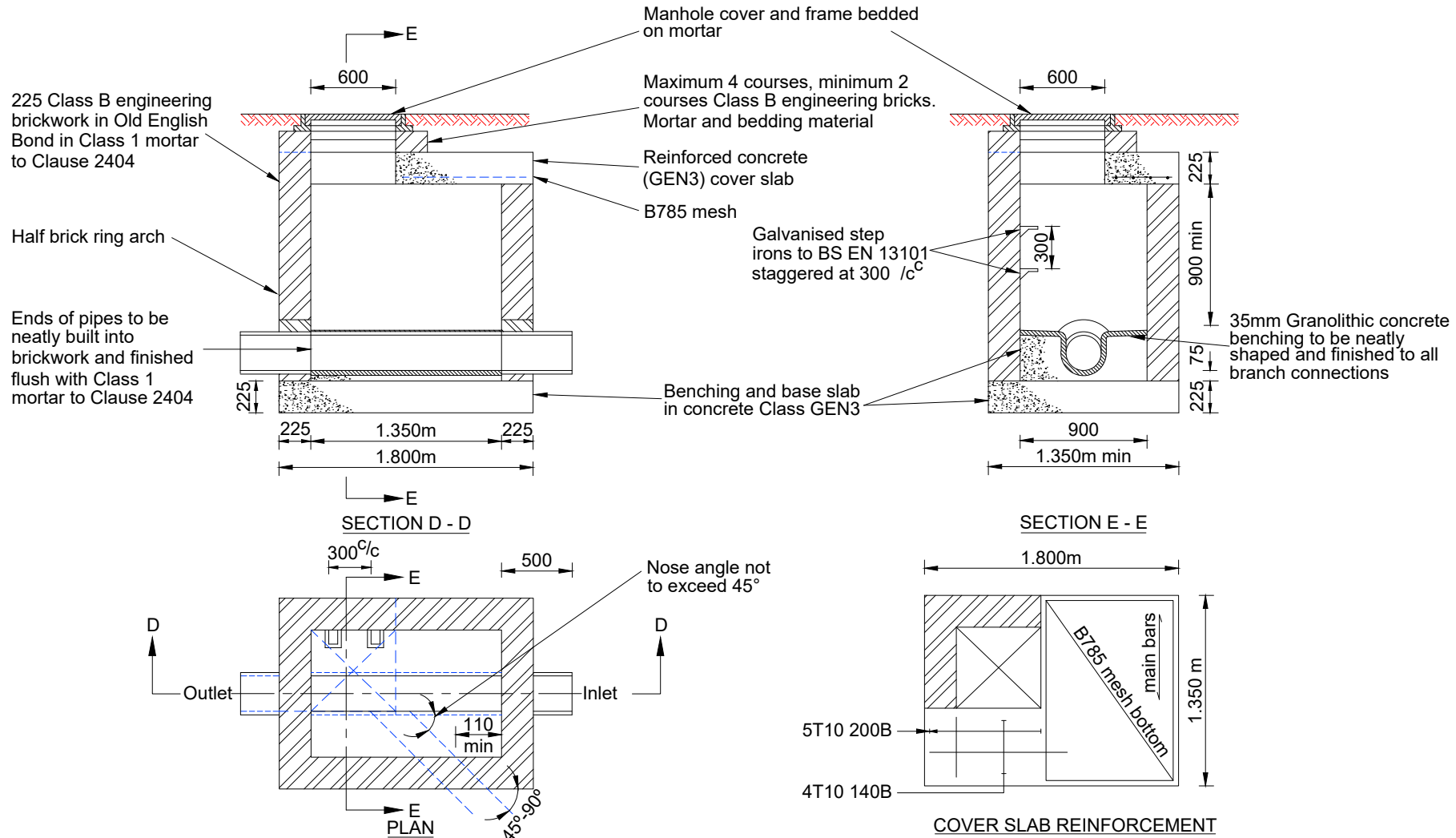

Revisions

- A - AUG 23 UPDATED DETAIL
- B -
- C -

Drawing Title

MANHOLES GROUP MH1
BRICK MANHOLE
TYPE B

Dwg No: HST/0500/001

Scale at A4 : N.T.S.

Drawn RD	Approved JE	Revised
Checked STM	Date JULY '11	Date



COUNTY HALL
Pegs Lane
Hertford, Herts
SG13 8DN
Phone: 01992 555555