

**RIGHT HAND TAPERS - R1 AND R2**  
(SCALE 1:10)

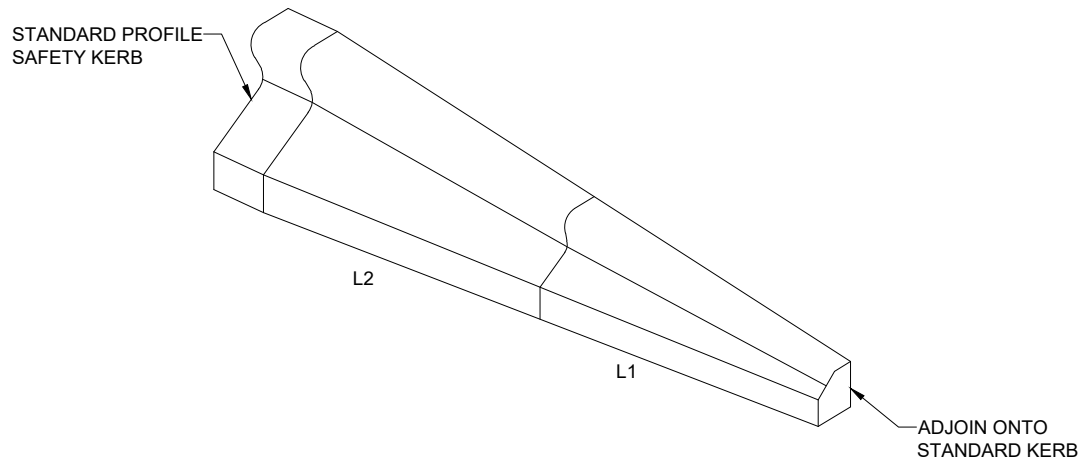

**LEFT HAND TAPERS - L1 AND L2**  
(SCALE 1:10)

**NOTES:**

1. ALL DIMENSIONS ARE IN MILLIMETRES UNLESS OTHERWISE STATED.
2. THE SURFACE FINISH TO COMPLY WITH BS 8100 - TYPE C.
3. REFER TO HST1100\004 MAXIMUM TAPERS HEIGHTS TO MATCH EITHER TYPE 1 OR TYPE 2.
4. THE MINIMUM COMPRESSIVE STRENGTH OF SAFETY KERB IS 55N/MM2 AT 28 DAYS.
5. SAFETY KERB 450MM LONG TO BE USED ON RADII EXCEEDING 7M BUT NOT EXCEEDING 12M.



COUNTY HALL  
Pegs Lane  
Hertford, Herts  
SG13 8DN  
Phone: 01992 555555

Revisions

A -	FEB 20	REVISED DETAIL
B -		
C -		

Drawing Title

TYPICAL PRECAST HIGH  
CONTAINMENT KERBS - TAPER

Dwg No: HST/1100/005

Scale at A4 : 1:10

Drawn	Approved	Revised
YS	HH	A
Checked	Date	Date
KK	JULY 11	FEB 20