

At Original Drawing Size This Line Measures 100mm

Original Drawing Size A3

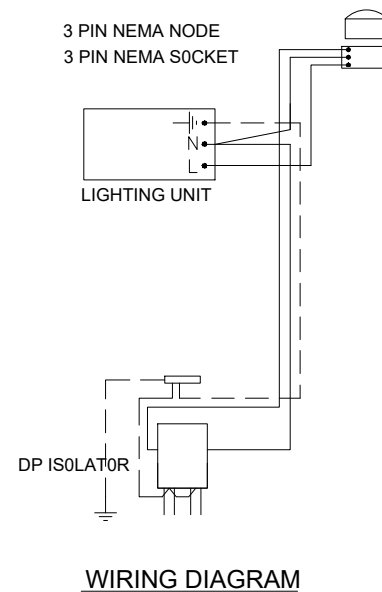
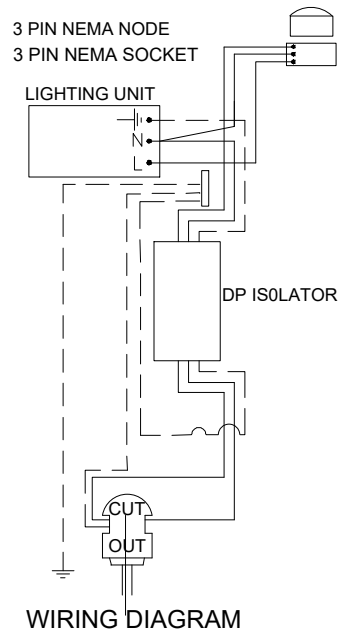
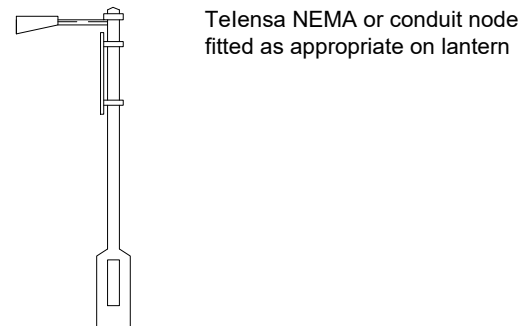

NOTES:

1. Test tags to be fitted indicating month and year of the test and next test date due
2. Telensa node (programmed for Hertfordshire) OSID number (TELENSA on drawing) to be affixed to the isolator, on the inside of the lantern and on the relevant paperwork
3. Label locations shown are indicative only and subject to supply type characteristics

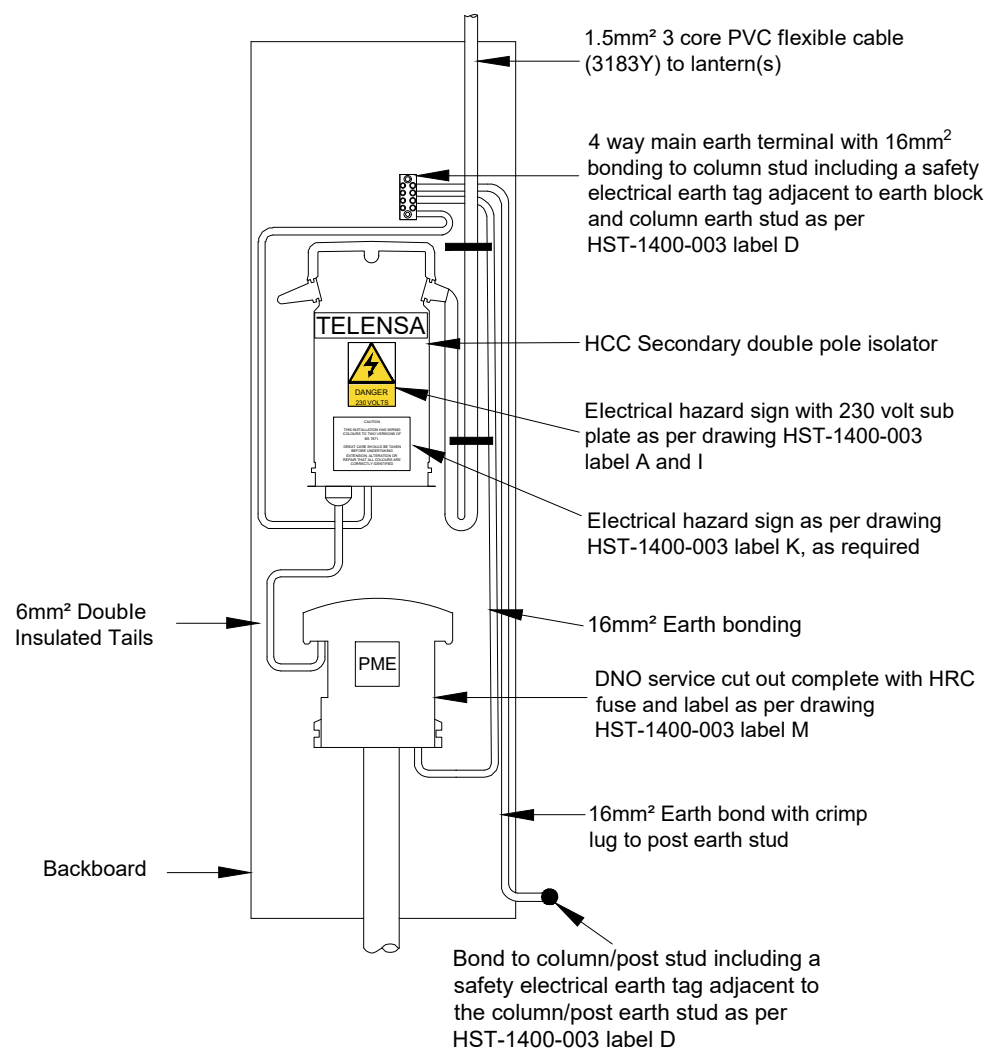

Wiring shall be kept in a neat and orderly manner by means of cable ties and be kept to one side of the equipment.

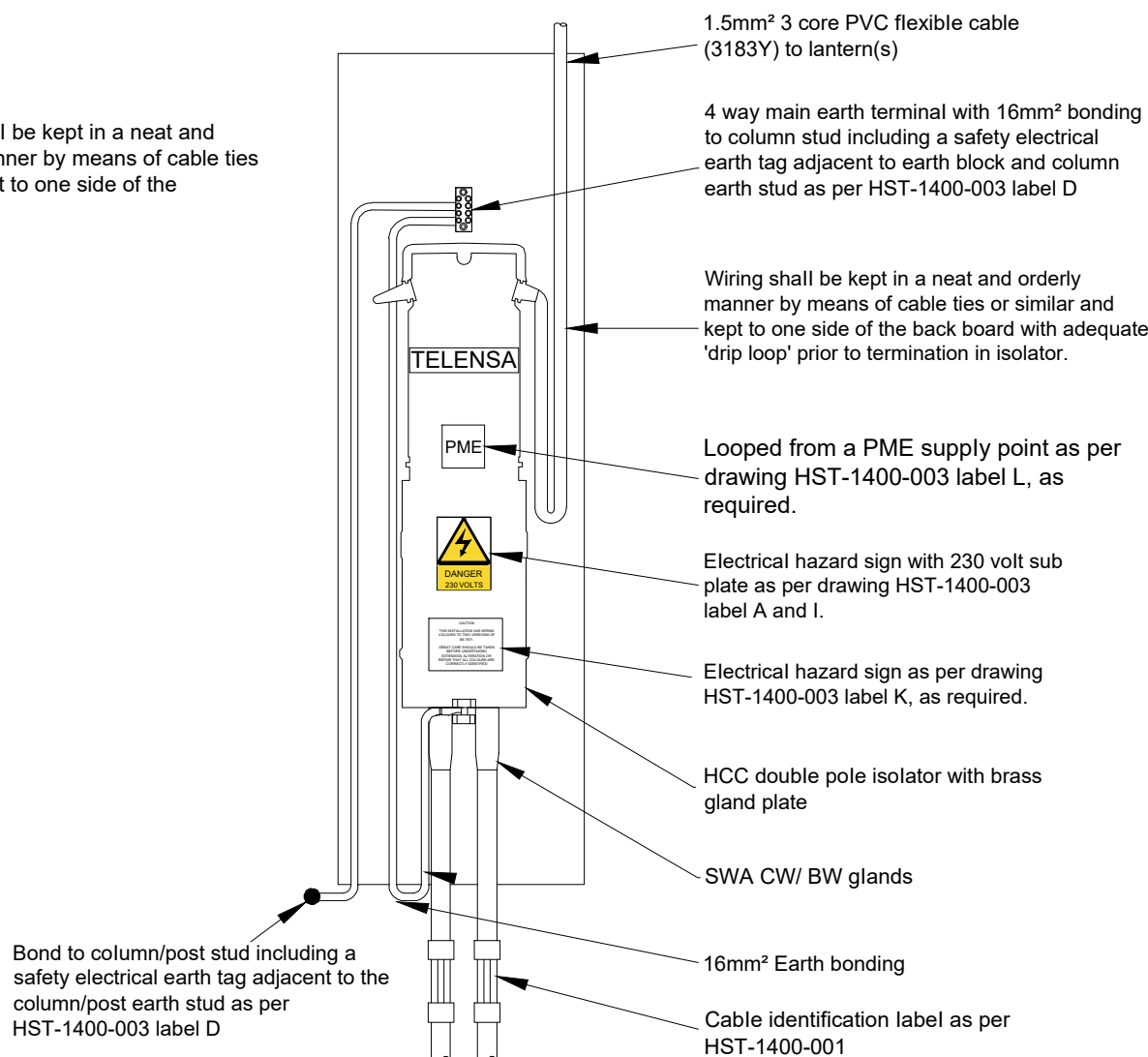

Wiring shall be kept in a neat and orderly manner by means of cable ties and be kept to one side of the equipment

Notes

A	Various drawing revisions	AS	RC	DOK	07/21
	Description	Dwn	Chk	App	Date

IWP No.	CAD	Drawn	Checked	Approved
	PB	PB	ADS	PW
Date	04/10	04/10	04/10	04/10
Sht No.	1 OF 1			
Scales	NTS			

Drg. No.	HST-1400-016
Rev.	A
Project Title	HCC STANDARD DETAIL DRAWINGS
Drawing Title	SIGN POST TERMINATIONS



COUNTY HALL
Pegs Lane
Hertford, Herts
SG13 8DN
Phone: 01992 555555